

W. L. SCHELLENBACH.  
STOP MOTION FOR TURRET LATHES.

(Application filed Jan. 27, 1900.)

(No Model.)

2 Sheets—Sheet 1.

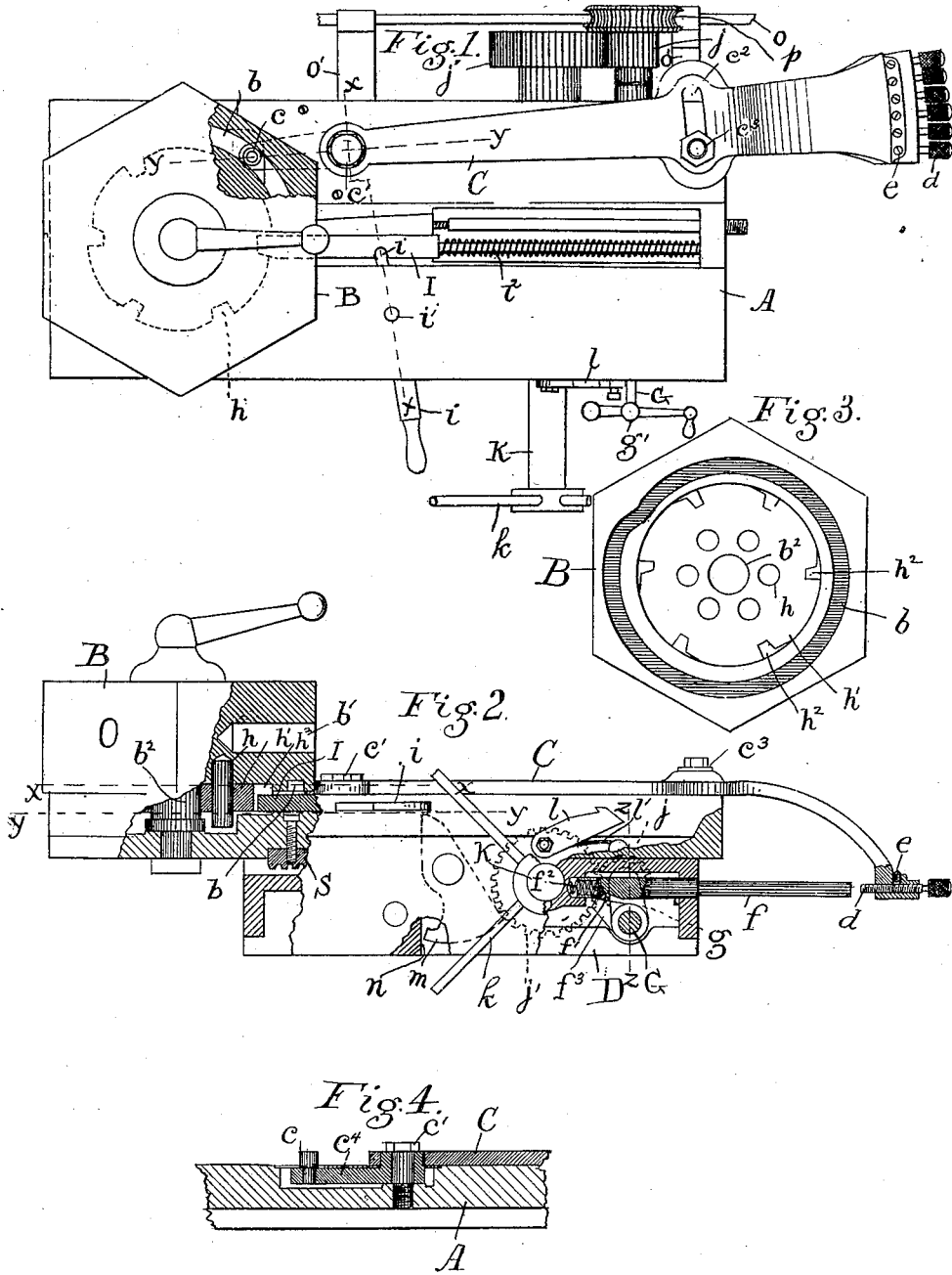

Witnesses:  
G. B. Bates  
L. M. Lodgey.

Inventor:  
William L. Schellenbach  
by G. B. Bates  
his atty.

W. L. SCHELLENBACH.  
STOP MOTION FOR TURRET LATHES.

(Application filed Jan. 27, 1900.)

(No Model.)

2 Sheets—Sheet 2.

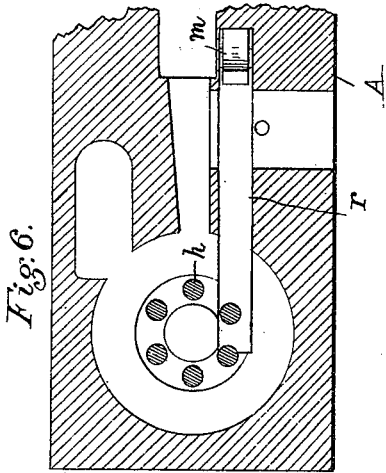

Fig. 6.

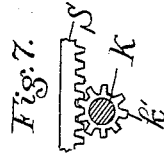

Fig. 7.

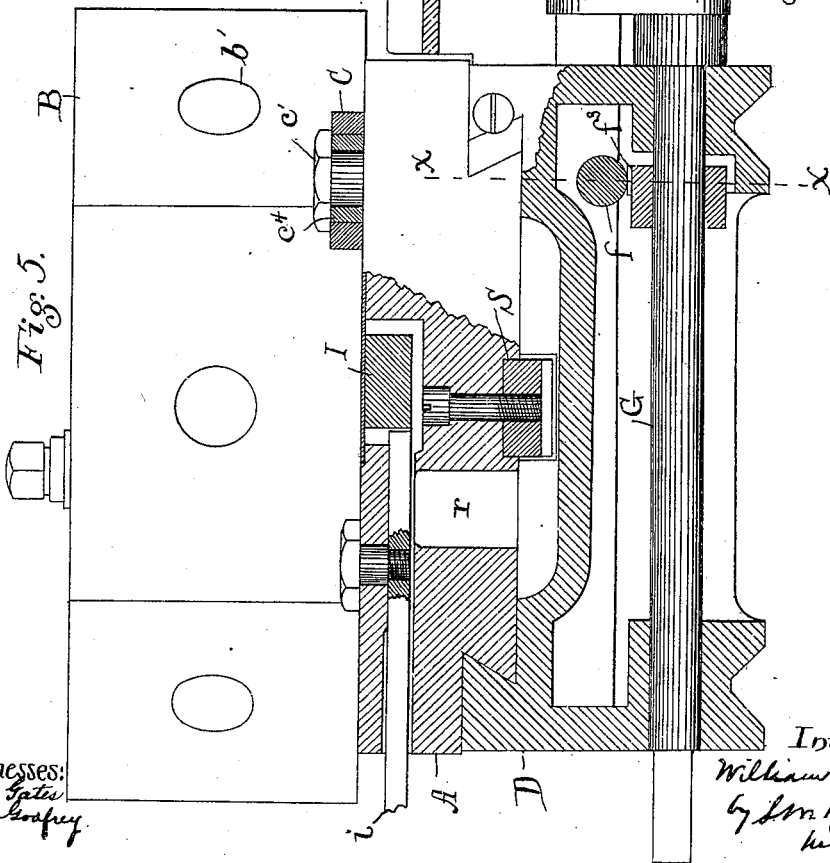

Fig. 5.

Witnesses:  
S. B. Gates  
C. M. Hooper

Inventor:  
William L. Schellenbach  
by J. M. Bates  
his atty.

# UNITED STATES PATENT OFFICE.

WILLIAM L. SCHELLENBACH, OF PHILADELPHIA, PENNSYLVANIA.

## STOP-MOTION FOR TURRET-LATHES.

SPECIFICATION forming part of Letters Patent No. 648,178, dated April 24, 1900.

Application filed January 27, 1900. Serial No. 2,957. (No model.)

*To all whom it may concern:*

Be it known that I, WILLIAM L. SCHELLENBACH, a citizen of the United States of America, and a resident of Philadelphia, county of Philadelphia, and State of Pennsylvania, have invented certain new and useful Improvements in Stop-Motions for Turret-Lathes, of which the following is a specification.

My invention relates to turret-lathes and to stop mechanism for the same of that class wherein independent adjustable stops are provided, one for each tool, for limiting the forward movement of the turret, each stop acting to automatically stop the turret at the desired point when the face or tool to which it corresponds and for which it acts is in operation.

The object of the invention is to devise improved mechanism for automatically stopping the forward motion of the turret when each tool has done its work by disconnecting the feed mechanism; and a further object is to automatically unlock and revolve the turret by the same motion by which the slide is drawn back. I accomplish these objects by means of the mechanism hereinafter described and claimed.

For the purpose of illustrating my invention I show in the accompanying drawings so much of a turret-lathe as is necessary to understand the nature of my improvement.

Figure 1 is a top view of the turret-slide with the turret mounted thereon, a portion being in section on the line  $xx$  of Fig. 2 and the housing shown in Fig. 5 being omitted to show the working parts. Fig. 2 is a side view of the same, showing the slide-block, a portion at the left hand of the figure being shown as a central vertical section and a portion at the right of the figure being shown in section on the line  $xx$  of Fig. 5. Fig. 3 is a view of the under side of the turret. Fig. 4 is an enlarged section on the line  $yy$  of Fig. 1. Fig. 5 is an enlarged section, the lower slide being shown on the line  $zz$  of Fig. 2 and the upper slide on the line  $xx$ , Fig. 1. Fig. 6 is a partial section on the line  $yy$  of Fig. 2, and Fig. 7 is a detail showing the connection of the rack and pilot-shaft.

D represents the lower slide, and A the turret or upper slide, of a turret-lathe, which

may be of any desired construction, and B is the turret, mounted on the upper slide in the usual manner by means of a stud  $b^2$ . The faces of the turret are provided with tool-openings  $b'$ , here shown as six in number, one for each face of the turret.

Mechanism is provided for automatically regulating the forward motion of the turret according to the tool which is in operation. For this purpose I provide a lever C, pivoted to the upper slide in rear of the turret by means of a pivot  $c'$ . As here shown, the lever is formed in two parts, the main portion extending back from the pivot to a point in the rear of the upper slide and resting on the upper surface thereof, the short arm of the lever  $c^4$  (see Fig. 4) extending forward below the upper surface of the slide to a point beneath the under side of the turret. The short arm  $c^4$  is formed with an upright-extending hub, which is keyed in a recess formed in the main portion of the lever.

On the forward end of the short arm  $c^4$  is an antifriction-roll  $c$ , which runs in the cam-groove  $b$ , formed on the under side of the turret. (See Fig. 3.) The cam-groove  $b$  is so formed as to throw the rear end of the lever C laterally from side to side as the turret turns. As here shown, the path of the cam, starting from its inner position, curves uniformly and spirally outward or away from the center until it reaches a point near the beginning, when it makes a sharp curve and comes back to the point of starting. Thus the movement of the lever will be uniform throughout the entire revolution of the turret and it will move one-sixth of its entire throw while the turret is revolving one-sixth of a revolution or from one position to the next in order, and at the end of the revolution of the turret it will come back to the point of beginning.

On the rear end of the lever C are adjustable stops adapted to strike the turret-slide stop  $f$  in succession, according to the position of the turret and of the lever C. As here shown, the rear end of the lever is turned down and broadened out, and extending through it in the general direction of its length is a series of adjustable screw-stops  $d$ , six in number, one for each face of the turret, said stops being disposed side by side in substantially the same horizontal plane.

Their forward ends project forward of the downturned end of the lever, and they are in the same horizontal plane as the turret-slide stop *f*, which is connected in the manner hereinafter shown with the turret-slide stop mechanism. These stops *d* are held from turning by set-screws *e* and are provided at their rear ends with milled heads by which they may be easily manipulated. The rear portion of the lever C is guided and steadied by means of a stud *C*<sup>3</sup>, which plays in a transverse slot *c*<sup>2</sup>, formed in the rear portion of the lever, where it rests on the top of the turret-slide. The stud *c*<sup>3</sup> is set in the top of the upper slide, and it is provided with a nut to hold the lever down.

In operating the lathe it will be understood that the several stops *d* are set to limit the forward motion of the lathe, according to the work to be done by the tool, which the particular stop regulates, so that each tool will travel only so far as is necessary to do the work required of it.

The lever C is here shown as being on top of the turret-slide; but it may be otherwise disposed, if desired.

The turret is fed by means of a pilot-shaft K, journaled in the lower slide and having a pinion *k*, Fig. 7, adapted to engage the rack S, secured to the under side of the upper slide. The pilot-shaft is provided with a hand-wheel *k* on one end, and on the other end is a spur-gear *j*, which receives power from a pinion *j*, which is secured to a worm-wheel *p*. The pinion *j* and the worm-wheel *p* are journaled on the crank-pin *g*, which is secured to the crank *g* on the end of the rocker-shaft G. The spur-wheel receives power from the worm *o*<sup>3</sup> on the shaft *o*, which is journaled in suitable bearings, as *o*<sup>1</sup>, and is connected by suitable means with the main spindle of the lathe. The worm is mounted on the shaft *o* by means of a spline *o*<sup>3</sup>, so that it may be free to slide longitudinally on the shaft. The rocker-shaft G is held normally in such a position as to hold the pinion *j* into engagement with the spur-gear *j*, and when the shaft is released, so that it is free to turn, the pinion disengages itself from the spur-gear and stops the feed of the turret.

The shaft G is held in position to lock the pinion *j* by means of the stop-rod *f*, before referred to. The rod is slidably mounted in the rear end of the lower slide above the shaft G in a position where it may be struck and pushed inward by one of the stops *d*. It is provided with a spring *f*<sup>2</sup>, by which it is pressed normally backward, and when in this position the cylindrical portion of the rod forms a stop or rest, against which rests the end of the dog *f*<sup>3</sup>, which is secured on the shaft G. Directly in rear of the normal point of contact of the shaft and the dog is formed a releasing-notch *f*<sup>1</sup>, into which the dog slips when the stop-rod is pressed forward by one of the stops *d*, thus allowing the shaft to turn enough to disengage the pinion *j* from the

gear *j*<sup>1</sup> and so stop the lathe. The front end of the shaft G is provided with a handle *g*<sup>1</sup>, (shown in Fig. 1,) by which the turret may be started and stopped at any desired point.

Mechanism is provided for automatically revolving the turret when the upper slide moves back.

The turret is locked in position by a locking-bolt I, which is slidably mounted in the upper slide and which engages notches *h*<sup>2</sup>, formed in the index-plate *h*<sup>1</sup>, said plate being secured to the under side of the lathe. The index-plate has one notch for each face, and the locking-bolt is provided with a spring by which the bolt is forced into engagement with the notches. The bolt is drawn back to unlock the turret by means of a lever *i*, pivoted to the upper slide by a pivot *i*<sup>1</sup> and extending horizontally out in front of the slide. For the purpose of automatically withdrawing the bolt, I provide a latch *l*, pivoted to the lower slide in such a position that it will engage the lever *i* when the slide is moved back and so will release the bolt from the turret and allow it to revolve.

For the purpose of automatically revolving the turret, I insert in the bottom of the turret a series of pins *h*, one for each face of the turret, the said pins projecting vertically down through the index-plate and from the under side of the turret. When the upper slide is drawn back, the pin *h*, which is next to the center, comes in contact with the upper end of the turret-dog *m*, Fig. 2, pivoted to the lower slide, and as the slide continues to move back the turret turns one-sixth of a revolution and the locking-bolt drops into the next notch. The dog is so located that it does not strike the pin until the turret has been released, and it is hung so that as the central pin moves forward over it when the turret revolves the dog will give way, but it will not move in the opposite direction when the pin comes against it.

The operation of the lathe will be evident from what has been said. As already explained, the stops *d* impinge against the end of the stop-rod successively as the turret revolves, stopping the feed automatically according to the tool which is in the working face. The sliding of the rod *f* forward releases the dog *f*<sup>3</sup> and disengages the pinion *j* from the gear *j*<sup>1</sup>, thus stopping the feed. The upper slide is then turned back by hand until the turret is unlocked and revolved one notch, when the handle *g*<sup>1</sup> is turned, releasing the dog *f*<sup>3</sup> from the notch *f*<sup>1</sup> and allowing the spring *f*<sup>2</sup> to force the stop-rod back into position for locking the dog. The feed is thus started, and the stop-rod is set in position, to be again tripped by the next stop.

I claim—

1. In a stop mechanism for turret-lathes, the combination with the turret-slide, the turret mounted thereon and a turret-slide stop, of a lever pivoted to said slide and having on the rear end thereof a series of adjustable

stops corresponding with the several faces of the turret, a cam on said turret adapted to engage the forward end of said lever, and to swing the rear end of said lever to bring each  
5 of said adjustable stops in line with the turret-slide stop when its corresponding turret-face comes into operative position.

2. In a stop mechanism for turret-lathes, the combination with the turret-slide, a turret  
10 mounted thereon and a turret-slide stop, of a lever pivoted to said slide and having on the rear end thereof a series of adjustable stops corresponding with the several faces of the turret, a grooved cam on the under side  
15 of said turret, a roll on the forward end of said lever adapted to engage the groove of said cam, said cam being so formed as to bring each of said adjustable stops in line with the turret-slide stop when its corresponding turret-  
20 face comes into operative position.

3. In a stop mechanism for turret-lathes, the combination with the turret-lathe and the turret mounted thereon, of a grooved cam formed on the under side of said turret, a lever  
25 pivoted to said slide and having a roll on its forward end adapted to engage the groove of said cam, the rear end of said lever being turned down and provided with a series of adjustable stops arranged side by side in substantially the same horizontal plane and a  
30 turret-slide stop in front of said adjustable stops and adapted to be struck by one or another according to the position of the lever.

4. In a stop mechanism for turret-lathes, the combination with the upper and lower  
35 turret-slides of a pilot-shaft for feeding the upper slide, a spur-gear on the pilot-shaft, a rocker-shaft journaled in the lower slide, a

driving-pinion on the crank of said rocker-  
shaft adapted to engage said spur-gear, a  
40 worm-wheel secured to said pinion, a worm connected to and driven by the lathe-spindle and engaging said worm-wheel, a locking-dog on the rocker-shaft for locking the driving-  
45 pinion in engagement with the spur-gear, a sliding stop-rod for retaining the dog in its locking position, a spring for forcing said rod normally backward, said rod being provided with a releasing-notch adapted to engage  
50 with said dog when the latter is not in its locking position and adjustable stops adapted to strike the stop-rod, substantially as described.

5. In a stop mechanism for turret-lathes, the combination with the upper and lower  
55 turret-slides of a pilot-shaft for feeding the upper slide, a spur-gear on the pilot-shaft, a rocker-shaft journaled in the lower slide, a driving-pinion on the crank of said rocker-  
60 shaft adapted to engage said spur-gear mechanism for imparting motion to said driving-pinion, a locking-dog on the rocker-shaft for locking the driving-pinion in engagement with the spur-gear, a sliding stop-rod for retaining the dog in its locking position a spring  
65 for forcing said rod normally backward, said rod being provided with a releasing-notch adapted to engage with said dog when the latter is not in its locking position and adjustable stops adapted to strike the stop-rod, sub-  
70 stantially as described.

WILLIAM L. SCHELLENBACH.

Witnesses:

JAMES F. COURTNEY,  
ADA H. CLONER.